

# KONDENSA HYBRID LKH

HYBRID WARM AIR HEATER

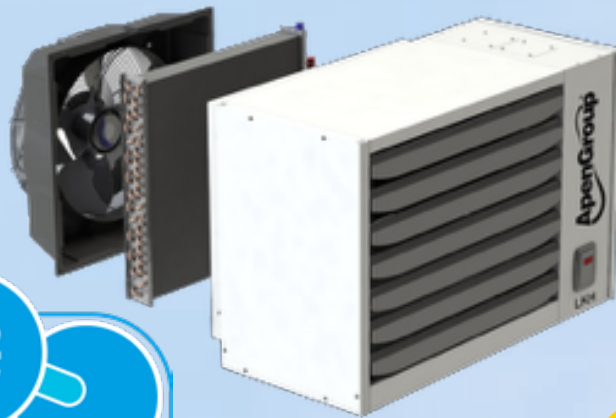

HEAT PUMP



OPTIONAL  
SMART X CONTROLS



ErP  
2021



# KONDENSA HYBRID LKH

## Hybrid warm air heaters

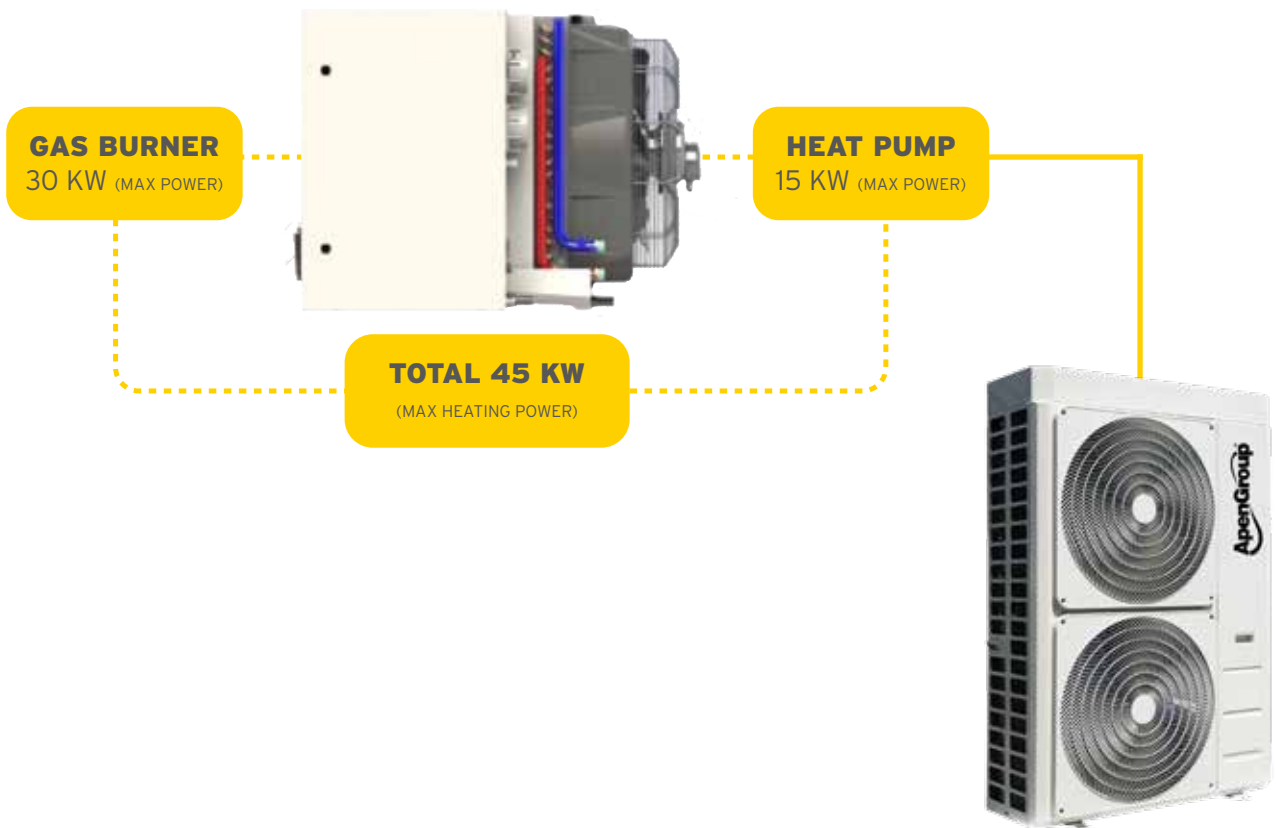

### POSSIBLE CONFIGURATION

- Standard with Apen Group Heat Pump
- Suitable for other heat pump brand.

### HEAT PUMP MADE BY APEN GROUP + CONDENSING WARM AIR HEATER

	Output Power (kW)	Water $\Delta T$ (°C)	Air $\Delta T$ (°C)	Water Flow (m <sup>3</sup> /h)	Water $\Delta P$ (kPa)	Air Flow (m <sup>3</sup> /h)
Heating	15+30 (45)	45/40	15	2,3	20	4500 @10V20
Cooling	12	07/12	11	2,3	20	1500 @4V

### CONDENSING WARM AIR HEATER

	Output Power (kW)	$\eta$	$\eta$ Seasonal h [Reg.UE/2281/2016]	NOx (% O <sub>2</sub> ) [hi]	NOx (% O <sub>2</sub> ) [hs]
Nominal heat input (MAX)	29	96%	93,10%	47 mg/kWh	42 mg/kWh
Nominal heat input (MIN)	7,5	108%		26ppm	24ppm

### HEAT PUMP MADE BY APEN GROUP

	Output Power (kW)	Water $\Delta T$ (°C)	Air $\Delta T$ (°C)	Water Flow (m <sup>3</sup> /h)	Water $\Delta P$ (kPa)
Heating	15	45/40	15	2,3	25
Cooling	12	07/12	11	2,3	25
Seasonal space heating energy			176%		
Energy efficiency class			A+++		

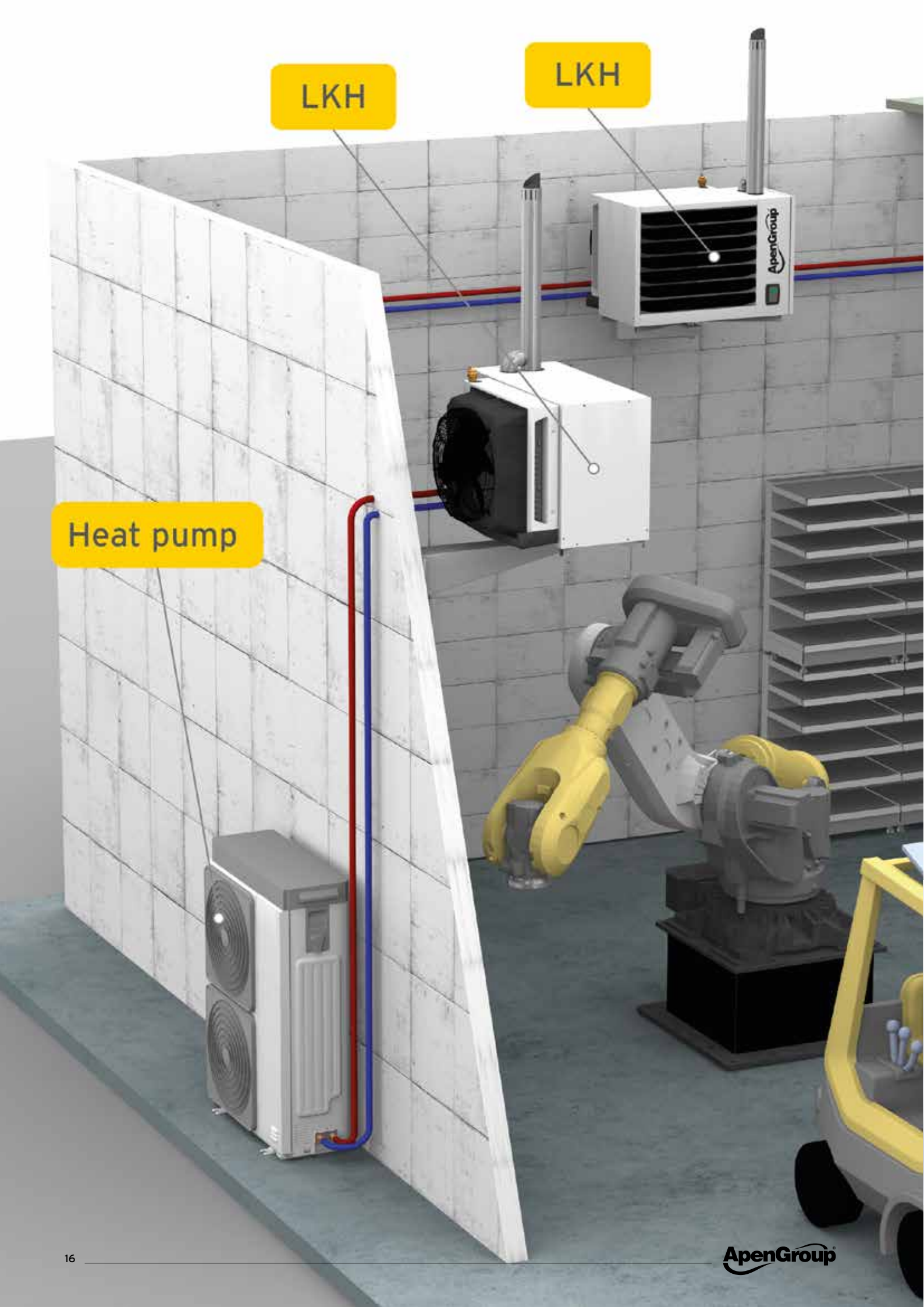

LKH

LKH

Heat pump

Heat pump

# KONDENSA HYBRID LKH / DIMENSIONS

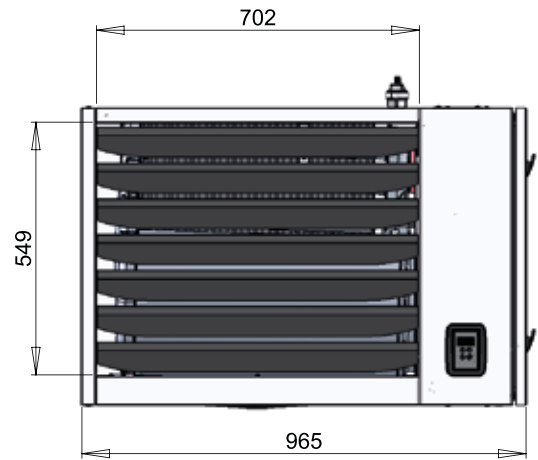
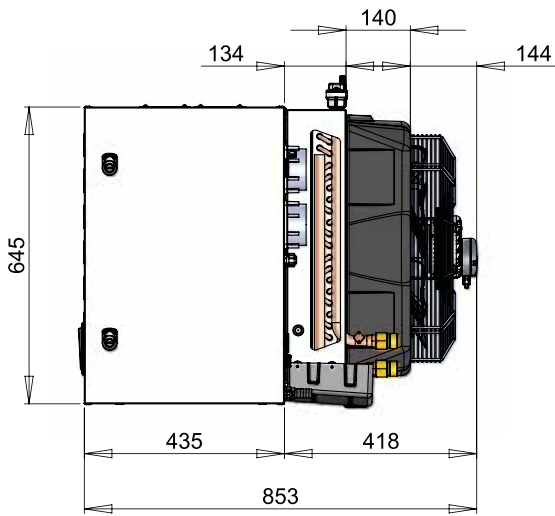

Model	Overall dimensions			Louvre		Rotating shelf			Fixed shelf
	H	L	DA	HB	LB	IS	ID	E	E
LKH044	645	965	143	550	700	445	445	530	410

