



reventon

INDUSTRIAL SOLUTIONS

Technical documentation

UNIT HEATERS IN STEEL CASING S-3S SERIES



MODELS:

S1-3S

S2-3S

S3-3S

S4-3S



EN CONTENTS

1. INTRODUCTION.....	3
1.1 GENERAL INFORMATION.....	3
1.2 STORAGE AND TRANSPORT.....	3
1.3 APPLICATION.....	3
2. DEVICE CHARACTERISTIC.....	3
2.1 PROTECTION DEGREE IP.....	3
2.2 CONSTRUCTION AND PRINCIPLE OF OPERATION.....	3
2.3 DIMENSIONS.....	3
2.4 TECHNICAL DATA.....	4
3. ASSEMBLY.....	5
3.1 GENERAL PRINCIPLES.....	5
3.2 WALL MOUNTING.....	5
3.3 CEILING MOUNTING.....	5
4. INSTALLATION.....	5
4.1 CONNECTION TO HEATING INSTALLATION.....	5
4.2 CONNECTION TO ELECTRICAL INSTALLATION.....	6
5. EXPLOITATION.....	6
5.1 EXPLOITATION PRINCIPLES.....	6
6. CONTROLS.....	6
7. WIRING DIAGRAMS.....	7

PL SPIS TREŚCI

1. WSTĘP.....	10
1.1 INFORMACJE OGÓLNE.....	10
1.2 PRZECHOWYWANIE I TRANSPORT.....	10
1.3 ZASTOSOWANIE.....	10
2. CHARAKTERYSTYKA URZĄDZENIA.....	10
2.1 STOPIEŃ OCHRONY IP.....	10
2.2 BUDOWA I ZASADA DZIAŁANIA.....	10
2.3 WYMIARY.....	10
2.4 DANE TECHNICZNE.....	11
3. MONTAŻ.....	12
3.1 ZASADY OGÓLNE.....	12
3.2 MONTAŻ ŚCIENNY.....	12
3.3 MONTAŻ SUFITOWY.....	12
4. INSTALACJA.....	12
4.1 PODŁĄCZENIE DO INSTALACJI GRZEWCZEJ.....	12
4.2 PODŁĄCZENIE DO INSTALACJI ELEKTRYCZNEJ.....	13
5. EKSPLOATACJA.....	13
5.1 ZASADY EKSPLOATACJI.....	13
6. AUTOMATYKA.....	13
7. SCHEMATY PODŁĄCZENIOWE.....	14

RU СОДЕРЖАНИЕ

1. ВВЕДЕНИЕ.....	17
1.1 ОБЩАЯ ИНФОРМАЦИЯ.....	17
1.2 ХРАНЕНИЕ И ТРАНСПОРТИРОВКА.....	17
1.3 ПРИМЕНЕНИЕ.....	17
2. ХАРАКТЕРИСТИКА УСТРОЙСТВА.....	17
2.1 СТЕПЕНЬ ЗАЩИТЫ IP.....	17
2.2 КОНСТРУКЦИЯ И ПРИНЦИП РАБОТЫ.....	17
2.3 РАЗМЕРЫ.....	17
2.4 ТЕХНИЧЕСКИЕ ДАННЫЕ.....	18
3. СБОРКА.....	19
3.1 ОБЩИЕ ПРИНЦИПЫ.....	19
3.2 НАСТЕННЫЙ МОНТАЖ.....	19
3.3 МОНТАЖ ПОТОЛКИ.....	19
4. УСТАНОВКА.....	19
4.1 ПОДКЛЮЧЕНИЕ К ОТОПЛИТЕЛЬНОЙ УСТАНОВКЕ.....	19
4.2 ПОДКЛЮЧЕНИЕ К ЭЛЕКТРИЧЕСКОЙ УСТАНОВКЕ.....	20
5. ЭКСПЛУАТАЦИЯ.....	20
5.1 ПРИНЦИПЫ ЭКСПЛУАТАЦИИ.....	20
6. АВТОМАТИКА.....	20
7. СХЕМЫ ПОДКЛЮЧЕНИЯ.....	21

DE INHALTSVERZEICHNIS

1. EINLEITUNG.....	24
1.1 ALLGEMEINE INFORMATIONEN.....	24
1.2 LAGERUNG UND TRANSPORT.....	24
1.3 ANWENDUNG.....	24
2. GERÄTEMERKMALE.....	24
2.1 SCHUTZART IP.....	24
2.2 KONSTRUKTION UND FUNKTIONSPRINZIP.....	24
2.3 ABMESSUNGEN.....	24
2.4 TECHNISCHE DATEN.....	25
3. MONTAGE.....	26
3.1 ALLGEMEINE GRUNDSÄTZE.....	26
3.2 WANDMONTAGE.....	26
3.3 DECKENMONTAGE.....	26
4. INSTALLATION.....	26
4.1 ANSCHLUSS AN DIE HEIZUNGSANLAGE.....	26
4.2 ANSCHLUSS AN DIE ELEKTRISCHE ANLAGE.....	27
5. BEDIENUNG.....	27
5.1 BETRIEBSANWEISUNGEN.....	27
6. REGELUNG.....	27
7. SCHALTPLÄNE.....	28

DECLARATION OF CONFORMITY EC.....	31
-----------------------------------	----

1. INTRODUCTION

1.1 GENERAL INFORMATION

The owner and the user of unit Reventon brand should read carefully this instruction and follow included guidelines. In case of any doubts, please reach out directly to the manufacturer i. e. company Reventon Group Sp. z o. o.

 The key recommendations from safety point of view are marked with the warning triangle (like the one on the left). It enables quick and easy localization of these recommendations and remind of them before interference with the unit.

 For the same reason, the requirements for periodic inspection and maintenance of the device, are marked with the wrench symbol (like the one on the left).

 During installation, usage or maintenance of the heater, all local safety requirements must be respected.

The product was made in Poland.

This documentation was developed by the company Reventon Group Sp. z o. o. – all rights reserved. The company Reventon Group Sp. z o. o. reserves the rights to make changes in the technical documentation.

1.2 STORAGE AND TRANSPORT

The product must be stored and transported on an appropriate pallet, in ambient temperature ranging from -30°C to 60°C and relative humidity ≤ 90%.

 During carrying of the heater, it must not be held by the coil's connectors. Due to its weight, the heater should be handled by two people.

1.3 APPLICATION

The device S-3S is designed for industrial indoor usage. It can be used for the heating or cooling spaces such as: production halls, warehouses, commercial room, service spaces, garages, workshops, etc. However, heating device should not be used to remove technological impurities such as dust or aggressive and explosive chemicals. It should neither be used in corrosive environments for aluminum, copper and steel as well as in highly dusty environments (above 0.3 g/m³). The device cannot be also used in places, where it would be exposed to too high humid (relative humidity higher than 90%) or direct contact with water, exceeding the permissible contact due to the protection degree IP (see next section).

2. DEVICE CHARACTERISTIC

2.1 PROTECTION DEGREE IP

IP determines the tightness of the electrical device (like fan motor), which is defined by two digits:

- **first characteristic digit** - specifies protection of the device against direct access to its interior as well as against penetration of smaller solids (such as dust)
- **second characteristic digit** - determines resistance of the engine to water ingress, i. e. its waterproofness

The motor of the fan used in S-3S with IP 54 has the following protection:

- Enclosure protected against ingress of dust in harmful quantities.
- Water splashed against the enclosure from any direction shall have no harmful effects.

2.2 CONSTRUCTION AND PRINCIPLE OF OPERATION

Casing: made of galvanized steel casing, powder painted in RAL 9005 color.

Air stators: made of galvanized steel casing, powder painted in RAL 7048 color. It is possible to adjust manually the air stators to achieve the needed direction of the air flow.

 The stators must be deflected at least 20° before the start-up of the fan.

Heating coil: made of copper and aluminum. Supplied by distribution medium (heating or cooling), which circulates through the coil and releases or extracts heat from the air. Depending on dimensions of the device the heaters are equipped with 1, 2 or 3-row heating coils.

Axial blowing fan: made of steel. The objective of the fan is to ensure air flow through the exchanger. It has a single-phase, three speed motor. Fans have diameter 300 mm (S1-3S), 350 mm (S2-3S and S3-3S) and 400 mm (S4-3S).

Rotating mounting bracket (optional equipment): enables the device to be installed in several configurations (depending on the requirements) and the unit to be rotated in a horizontal plane.

Fixed holders (optional equipment): made of steel, element for mounting the device on a wall or ceiling. Solid and durable construction that allows you to attach the device to the wall or ceiling. With their help, it is possible to adjust the tilt angle of the device within a range of 15 degrees.

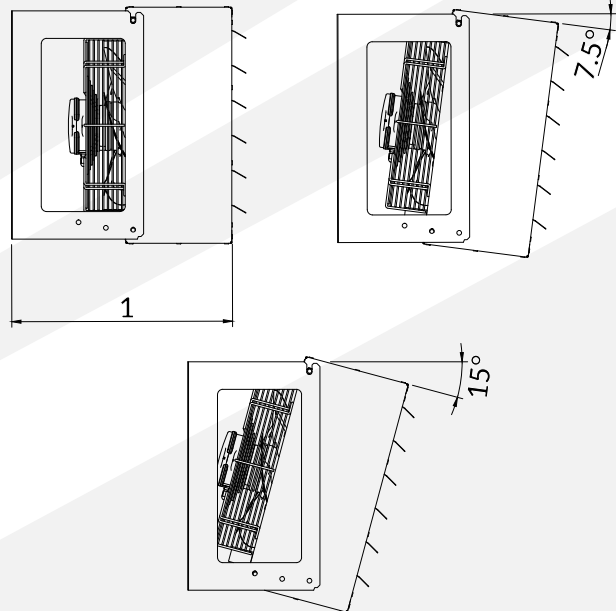

	S1-3S	S2-3S/S3-3S	S4-3S
1	419.5 [mm]	469.5 [mm]	467.5 [mm]

2.3 DIMENSIONS

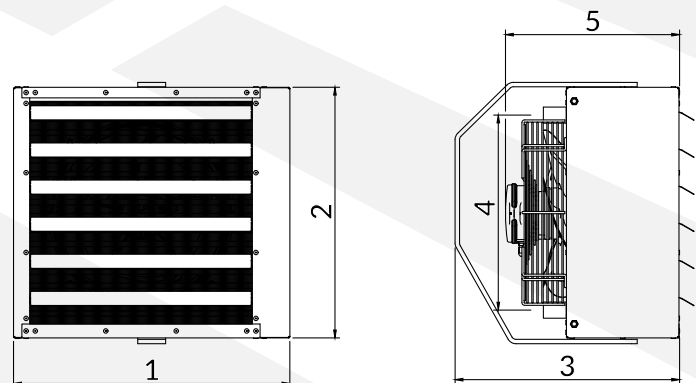

	1	2	3	4	5
S1-3S [mm]	496	450	403	350±3	312.5
S2-3S/S3-3S [mm]	546	550	480	450±3	367
S4-3S [mm]	696	660	549	560±3	375

2.4 TECHNICAL DATA

TECHNICAL DATA		S1-3S	S2-3S	S3-3S	S4-3S
Product code		WHS1-3S-1789	WHS2-3S-1790	WHS3-3S-1791	WHS4-3S-1787
Nominal heating capacity [kW] *	III STAGE	14.7	23.4	36.9	50.1
	II STAGE	13.1	16.0	20.8	38.5
	I STAGE	11.3	14.0	17.8	27.5
Heating capacity range [kW]**		1.57 – 19.5	2.1 – 30.8	2.92 – 48.8	4.17 – 66.2
Maximum airflow [m³/h]	III STAGE	1400	2000	1800	3350
	II STAGE	1150	1100	850	2250
	I STAGE	900	900	700	1400
Maximum horizontal range [m]		10	13	11	18
Number of rows [pcs.]		1	2	3	2
Capacity of water [dm³]		0.5	1.3	1.9	2.0
Maximum temperature of working fluid [°C]		120	120	120	120
Maximum working pressure [MPa]		1.6	1.6	1.6	1.6
Connection diameter ["]		3/4	3/4	3/4	3/4
Supply voltage [V] / Supply frequency [Hz]		230/50	230/50	230/50	230/50
Nominal motor current [A]	III STAGE	0.38	0.58	0.58	0.82
	II STAGE	0.20	0.34	0.34	0.62
	I STAGE	0.15	0.30	0.30	0.41
Nominal motor speed [rpm]	III STAGE	1350	1400	1400	1380
	II STAGE	1130	1100	1100	1030
	I STAGE	870	850	850	650
Nominal motor power [W]	III STAGE	75	124	124	185
	II STAGE	45	85	85	140
	I STAGE	35	75	75	90
Protection degree IP [-]		54	54	54	54
Net weight [kg]		12.5	19	20	25
Noise [dB]***	III STAGE	51	54	53	56
	II STAGE	45	48	47	50
	I STAGE	43	46	45	48

* for parameters 90/70°C and 0°C inlet air temperature

** max. 120/90°C, 0°C inlet air temperature, III stage // min. 40/30°C, 20°C inlet air temperature, I stage

*** measurement at the distance 5 m

Parameters	S1-3S III stage 1400 [m³/h]																			
	80/60					70/50					50/40					40/30				
Supply/return water temperature [°C]																				
Dry bulb air inlet temperature [°C]	0	5	10	15	20	0	5	10	15	20	0	5	10	15	20	0	5	10	15	20
Heating capacity [kW]	12.6	11.5	10.4	9.4	8.3	10.5	9.4	8.3	7.3	6.3	8.1	7.0	6.0	5.0	4.0	6.0	5.0	4.0	3.0	2.0
Dry bulb air outlet temperature [°C]	25.1	28.3	31.5	34.6	37.7	20.9	24.1	27.2	30.3	33.4	16.1	19.2	22.3	25.4	28.5	12.0	15.1	18.2	21.3	24.3
Water flow [m³/h]	0.55	0.51	0.46	0.41	0.36	0.46	0.41	0.37	0.32	0.27	0.70	0.61	0.52	0.43	0.35	0.52	0.43	0.34	0.26	0.17
Pressure drop in the heat exchanger [kPa]	12	10	9	7	6	9	7	6	5	4	20	16	12	8	6	12	9	6	3	2







Parameters	S2-3S III stage 2000 [m³/h]																			
	80/60					70/50					50/40					40/30				
Supply/return water temperature [°C]																				
Dry bulb air inlet temperature [°C]	0	5	10	15	20	0	5	10	15	20	0	5	10	15	20	0	5	10	15	20
Heating capacity [kW]	20.1	18.4	16.7	15.0	13.4	16.9	15.2	13.5	11.8	10.2	12.9	11.2	9.6	8.0	6.5	9.7	8.1	6.5	4.9	3.4
Dry bulb air outlet temperature [°C]	28.0	31.0	34.0	37.0	39.9	23.4	26.5	29.4	32.4	35.3	17.9	20.9	23.9	26.8	29.6	13.5	16.4	19.3	22.2	25.1
Water flow [m³/h]	0.88	0.81	0.73	0.66	0.59	0.74	0.66	0.59	0.52	0.45	1.12	0.98	0.84	0.70	0.56	0.84	0.70	0.56	0.43	0.29
Pressure drop in the heat exchanger [kPa]	7	6	5	4	3	5	4	4	3	2	12	9	7	5	3	7	5	4	2	1

Parameters	S3-3S III stage 1800 [m³/h]																			
	80/60					70/50					50/40					40/30				
Supply/return water temperature [°C]																				
Dry bulb air inlet temperature [°C]	0	5	10	15	20	0	5	10	15	20	0	5	10	15	20	0	5	10	15	20
Heating capacity [kW]	32.0	29.2	26.6	24.0	21.4	27.0	24.4	21.7	19.2	16.7	20.4	17.8	15.3	12.8	10.4	15.5	13.0	10.5	8.1	5.7
Dry bulb air outlet temperature [°C]	49.4	51.0	52.6	54.1	55.5	41.8	43.4	44.8	46.3	47.7	31.5	33.0	34.5	35.9	37.3	24.0	25.5	26.9	28.3	29.5
Water flow [m³/h]	1.40	1.28	1.17	1.05	0.94	1.18	1.07	0.95	0.84	0.73	1.77	1.55	1.33	1.12	0.91	1.35	1.13	0.91	0.70	0.50
Pressure drop in the heat exchanger [kPa]	15	13	11	9	7	11	9	8	6	5	25	20	15	11	7	16	11	8	5	3

Parameters	S4-3S III stage 3350 [m³/h]																			
	80/60					70/50					50/40					40/30				
Supply/return water temperature [°C]																				
Dry bulb air inlet temperature [°C]	0	5	10	15	20	0	5	10	15	20	0	5	10	15	20	0	5	10	15	20
Heating capacity [kW]	43.1	39.4	35.7	32.1	28.6	36.2	32.5	28.9	25.4	21.9	27.6	24.0	20.6	17.1	13.8	20.7	17.2	13.9	10.5	7.2
Dry bulb air outlet temperature [°C]	35.8	38.3	40.7	43.1	45.5	30.0	32.4	34.9	37.2	39.5	22.9	25.3	27.7	30.0	32.3	17.2	19.6	21.9	24.2	26.4
Water flow [m³/h]	1.90	1.73	1.57	1.41	1.26	1.58	1.42	1.26	1.11	0.96	2.40	2.09	1.79	1.49	1.20	1.80	1.49	1.20	0.91	0.63
Pressure drop in the heat exchanger [kPa]	17	14	12	10	8	12	10	8	6	5	27	21	16	11	8	16	12	8	5	2

3. ASSEMBLY

3.1 GENERAL PRINCIPLES

-  The heater should be assembled and disassembled by people experienced in mounting of such devices and - if local law requires it with appropriate qualifications.
-  Due to the relatively large weight and the dimensions of the heater, the assembly should be performed by at least two people and at least one of them must meet the requirements in the paragraph above.
-  It is the responsibility of the assemblers to make the mounting according to the guidelines from this instruction and in accordance with the local regulations in force.
-  During carrying of the heater, it must not be held by the coil's connectors.
-  The heater should be mounted in way providing the horizontal or the vertical air stream keeping the minimum gaps shown in the drawing at the end of this section. The heater must be mounted using elements with a load capacity appropriate to its weight.
-  The stators must be deflected at least 20° before the start up of the fan.

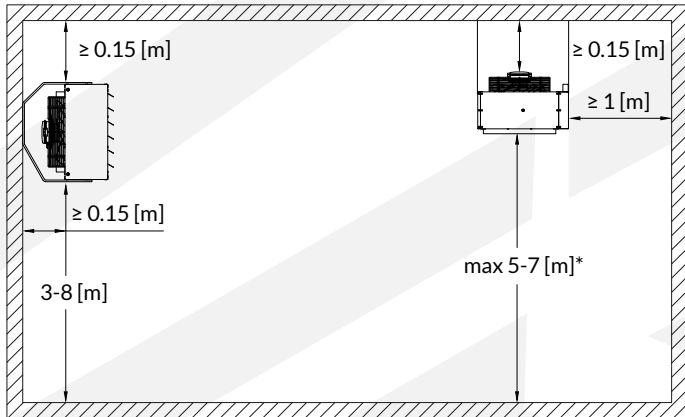

* the maximum vertical range depends on the model

3.2 WALL MOUNTING

The example below shows the wall mounting with the rotating mounting bracket and the fixed holders (it allows to adjust the degree of tilt of the device in a range of 15 degrees).

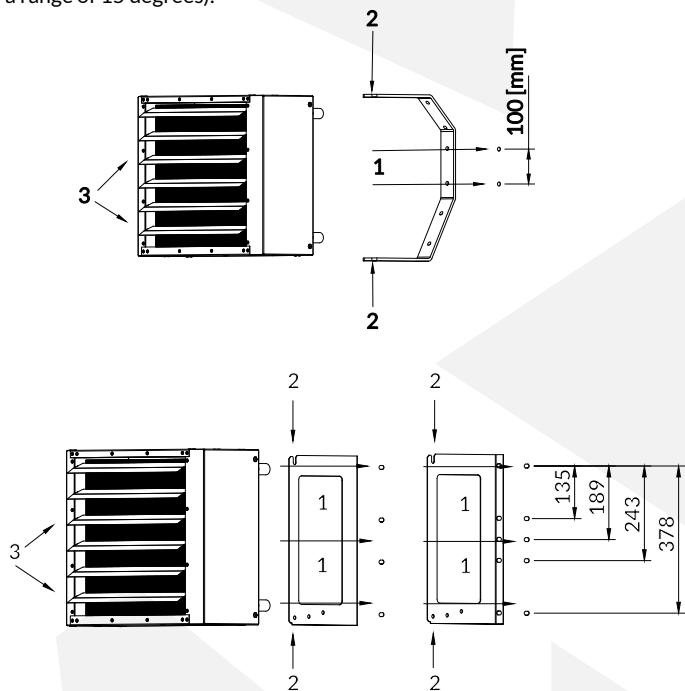

- 1 - The rotating mounting bracket or fixed holders should be attached to a partition with the appropriate load capacity (see the net weight of the heater in the section 2.4) with e. g. mounting pins and screws M8 x 80 [mm] (or longer).
- 2 - Hang the heater on the rotating mounting bracket or fixed holders using M8 bolts and spring washers (between the bracket and the bolt). Then turn the device on the bracket according to a required position and tighten the screws securely.
- 3 - Deflect stators at least 20° before the start-up of the fan to achieve the required stream shape.

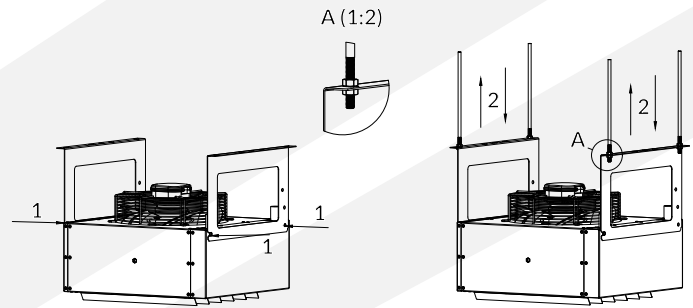

3.3 CEILING MOUNTING

The example below shows the ceiling mounting with the fixed holders and threaded rods.



- 1 - Attach the fixed holders, spring washers and tighten the screws.
- 2 - The heater is ready to mounting by the fixed holders.

4. INSTALLATION

-  Before connecting the unit to a heating and an electrical installation, it must be assembled permanently to a suitable partition (according to the recommendations contained in the section 3).
-  All installation, repairs and disassembly works, must be performed by qualified persons i. e. having the appropriate qualifications for these works. It is the responsibility of the installer to make the installation according to the guidelines from this instruction and in accordance with the local regulations in force.
-  Do not install, service or operate the device with wet hands or barefoot.

4.1 CONNECTION TO HEATING INSTALLATION

Below there is shown an example hydraulic diagram. It is just a recommendation, the final execution of installation and usage of individual components is decided by the HVAC designer.

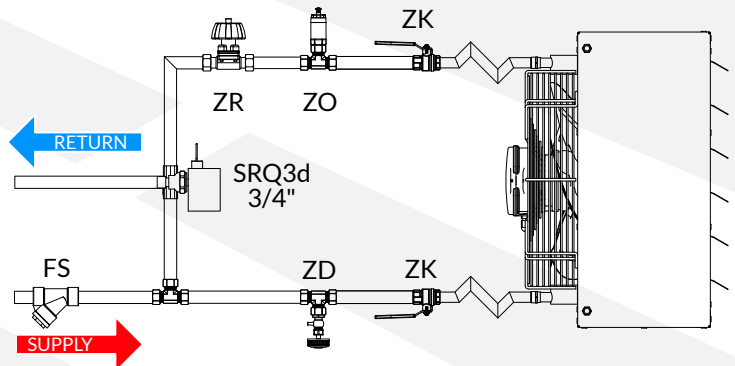



FS - mesh filter; ZO - vent valve; ZK - shut-off valve; ZD - drain valve; ZR - balancing valve; SRQ3d - three-way valve with an actuator



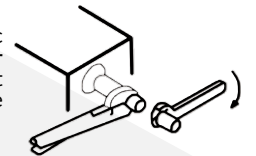

-  The hydraulic installation must be carried out in accordance with the state of the art and the local regulations in force.
- The pipes should be connected in accordance with the indicators on the heater (supply - marked in red, return - marked in blue).

-  Connecting the device to the hydraulic installation, do remember to hold the connector by a pipe wrench like it is shown in graphic. Not keeping to this recommendation may cause the damages of the coil.

















-  The hydraulic system should include all safety elements required by law (depending on the type of central heating installation and the type of heat source).
-  Before connecting the heater to an electrical installation, the leakage test of the hydraulic installation should be conducted.

4.2 CONNECTION TO ELECTRICAL INSTALLATION

-  The electrical installation must be carried out in accordance with the state of the art and the local regulations in force.
-  The electrical connection of heater to an installation with the electrical parameters according to the section 2.4 should be made in according to the appropriate connection diagram (see section 7).
-  The electrical circuit to which the device is connected, should include all safety element required by the law and the main ON/OFF switch enabling safe disconnection of the heater from the electrical system.
-  Before the start up, it is required to check the electrical installation and controls in terms of damaged insulation, incorrect connection in the terminals, risk of potential short circuits etc.

5. EXPLOITATION

5.1 EXPLOITATION PRINCIPLES

-  The user is obliged to be familiar with this instruction before exploitation of the device.
-  It is forbidden to touch the device during operation. Before any interference in the device, the electricity supply to the heater must be absolutely cut off. Components of the device may be warm after shutting down.
-  Device cannot be operated by children and adults with reduced mobility, sensual and intellectual. Access to the heater by parties like unauthorised people, children and animals is forbidden and should be prevented or at least hindered.
-  The device cannot work with covered or restricted air inlet or outlet (e.g. as a result of not keeping the minimum distances from partitions or obstructed inlet/outlet).
-  The unit is designed for handling of air at temperature ranging from -30°C to 60°C and with relative humidity ≤ 90%.
-  Keep the device away from water and its solutions and splashing or dripping liquids. Never put objects with liquids on top or close the device.
-  The heater has no antifreeze protection – as the heating medium should be used a fluid with a lower freezing point than the lowest probable temperature that may occur in the particular room.
-  In case of any malfunctions (like blow a fuse, unusual noise etc.), immediately cut off the device from the electrical system and contact directly with the installer, the manufacturer or the distributor. It is forbidden to turn on the unit before diagnosing and removing the reason of this malfunction.
-  If the device is not used for a longer time disconnect the unit from the electrical installation.
-  Periodical inspection and maintenance of the device according to the guidelines below, should be carried out with the given frequencies and always after two-weeks or a longer period of inactivity.
-  Before starting any maintenance work, the heater must be disconnected from the power supply.
-  At the periodic inspection and maintenance, the following should be successively done:
 - check the condition of the wiring for its damage and remove/repair any damage,
 - blow out the heat exchanger with the compressed air,
 - clean the remaining elements from residue with a soft cloth at least twice every year,
 - at least once per year, connect the device to the power supply and assess if the fan works correctly; additional murmur, metallic reverberation, grinding noise, vibration etc. says about a malfunction in such case, immediately cut off the device from the electrical system and contact directly with the installer, the manufacturer or the distributor.
-  Inspection and maintenance of the heater should be carried out by a user who is familiar with this instruction or by an external entity if due to the way of assembly or local regulations additional authorisations like e. g. working with electricity or at heights are required.
-  The frequency of the service should depend on the actual dirtiness - if the device is operating in an environment with a high concentration of dust, periodic cleaning should be performed much more often that it is specified above.

After exploitation time, please utilise the unit according to the local regulations.

6. CONTROLS

Using of control dedicated to UNIT HEATER S-3S SERIES gives vast possibilities of adjusting the efficiency of the unit in different degree of automation, depending on the needs.

3-STEP CONTROLLER WITH ROOM THERMOSTAT HC3S

Controller is used to regulate devices equipped with 3-stage fans. It has 3-stage speed control and built-in manual thermostat.



Voltage/ Frequency: 230 V AC / 50 – 60 Hz
Maximum current load: 3 A
Operating temperature range: -10°C - 60°C
Regulation range: 10°C - 30°C
Operating mode: continuous or thermostatic
Control accuracy: < 1°C
Dimensions: 130 x 85 x 40 mm
Weight: 210 g
Degree of casing's protection: IP 30

PROGRAMMABLE CONTROLLER HMI BMS

Controller is used to regulate devices equipped with 3-stage fans. Controller has functions like programmable mode, operation in heating, cooling or mixed mode, automatic selection of the fan speed and can be integrated with BMS building control system.



Voltage/ Frequency: 230 V AC / 50 – 60 Hz
Maximum current load: 5 A
Operating temperature range: 0 - 45°C
Regulation range: 5°C - 35°C
Regulation accuracy: ± 0.5°C
Additional temperature sensor: NTC 10K
Communication: RS485
Dimensions: 86 x 86 x 13.3 mm
Weight: 270 g
Degree of protection (housing): IP 20
Degree of protection (external sensor): IP 68

FAN SPEED CONTROLLER HC

Controller is designed to change the single-phase fan's speed voltage controlled in industrial supply and heating systems.



5 control levels: 80-105-135-170-230 V*
Voltage/ Frequency: 230 V AC / 50 – 60 Hz
Maximum current load (depending on model): 1.2 A, 3 A, 5 A, 7 A, 14 A
Protection: thermal switch
Weight (depending on model): 1.45 kg, 2.5 kg, 4.5 kg, 5.5 kg or 10.5 kg
Degree of protection: IP 54

* regulation for 3 A regulator: 115-135-155-180-230 V

MANUAL ROOM THERMOSTAT HC

Controls operation of the heater. Switches the unit off automatically when the set temperature is reached.



Voltage/ Frequency: 230 V AC / 50 – 60 Hz
Maximum current load: 3 A
Operating temperature range: 0 - 40°C
Regulation range: 10 - 30°C
Regulation accuracy: < 1°C
Degree protection: IP 30

ADDITIONAL ACCESSORIES

Two-way or three-way valve with actuator HC 3/4" - is used to automatically regulate the flow of the heating medium.

Relay module RM-16A - allows to connect a receiver with higher current consumption than permissible current load of connected controller.

Maintenance ON/OFF switch - is used to stop the machinery quickly when there is a risk of injury or the workflow requires stopping.

LEGEND

- 1 - voltage supply 230 V/50 Hz*
- 2 - maintenance ON/OFF switch
- 3 - unit heater S-3S
- 4 - 3-step controller with room thermostat HC3S
- 5 - valve with ON/OFF actuator

* the electrical circuit should include all safety element required by the law

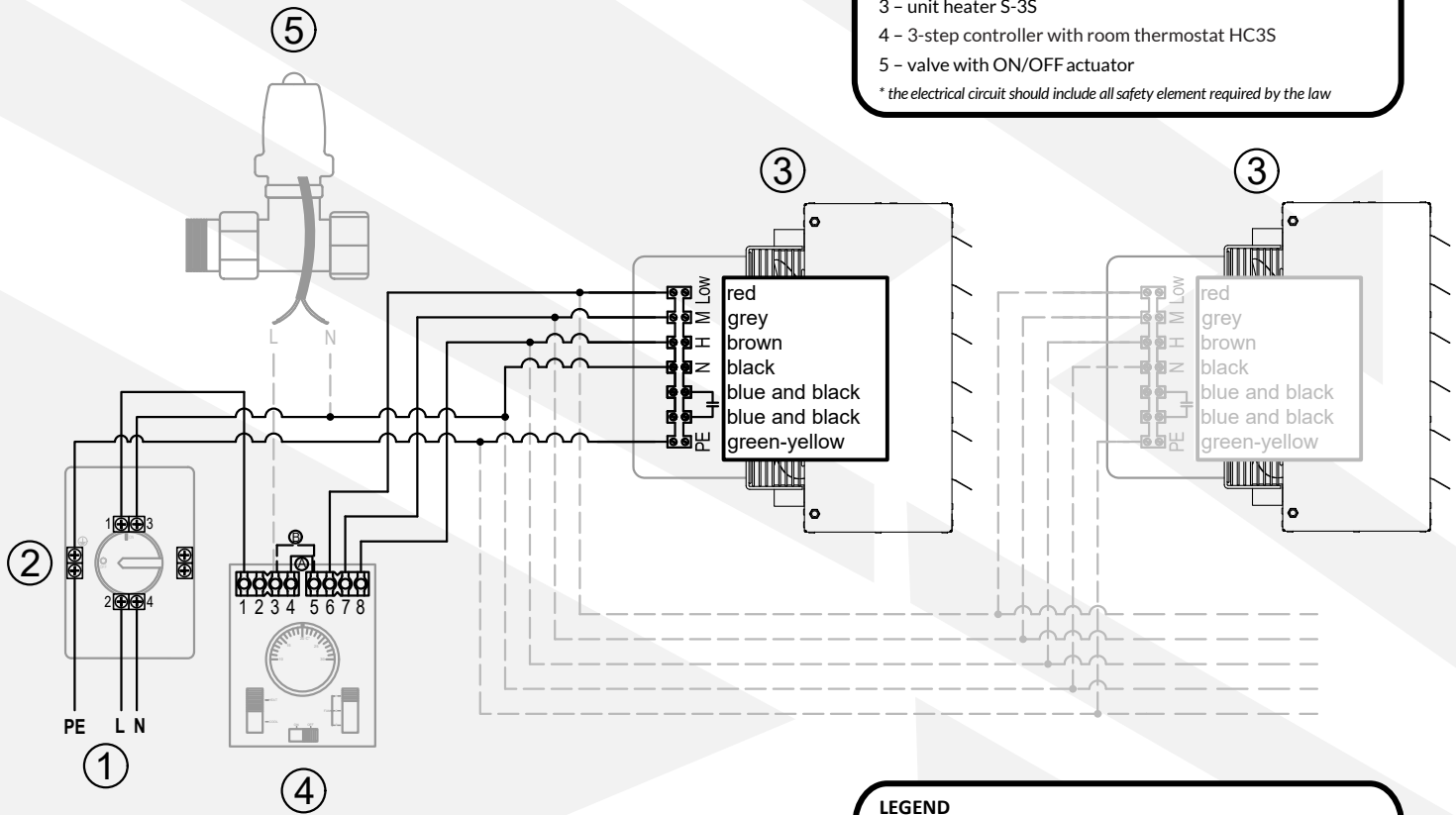

LEGEND

- 1 - voltage supply 230 V/50 Hz*
- 2 - maintenance ON/OFF switch
- 3 - unit heater S-3S
- 4 - 3-step controller with room thermostat HC3S
- 5 - valve with ON/OFF actuator
- 9 - relay module RM-16A

* the electrical circuit should include all safety element required by the law

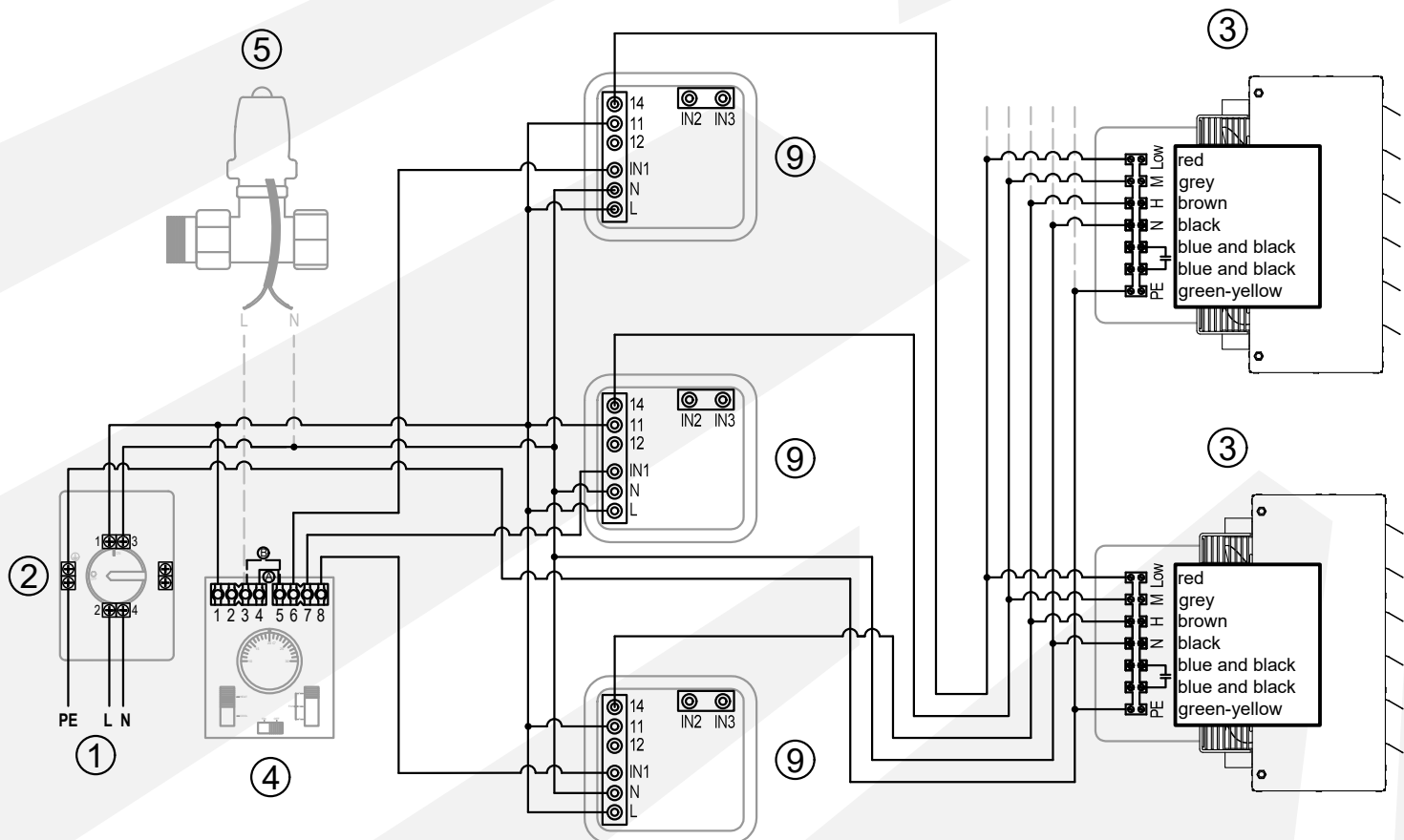

LEGEND

- 1 - voltage supply 230V/50 Hz*
- 2 - maintenance ON/OFF switch
- 3 - unit heater S-3S
- 5 - valve with ON/OFF actuator
- 8 - programmable controller HMI BMS
- 10 - external temperature sensor

* the electrical circuit should include all safety element required by the law

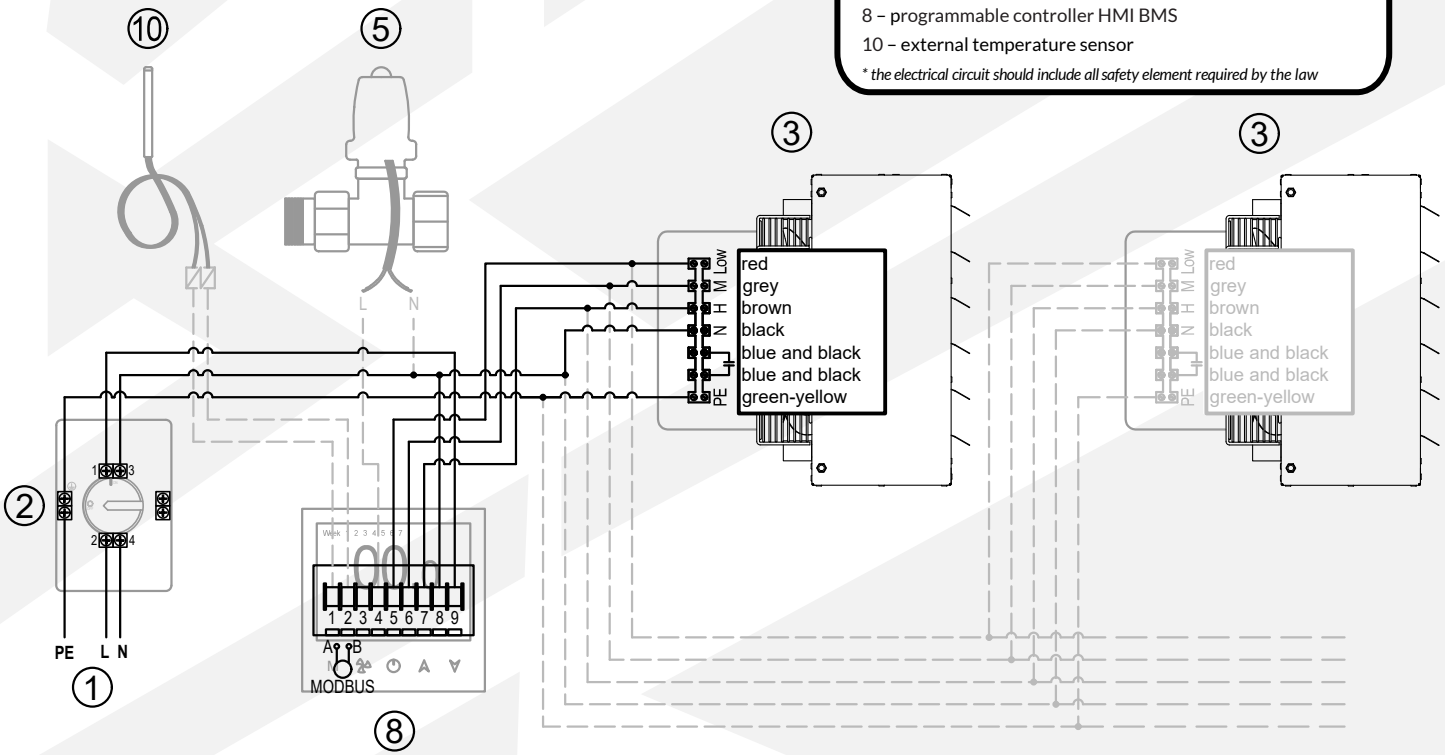

LEGEND

- 1 - voltage supply 230V/50 Hz*
- 2 - maintenance ON/OFF switch
- 3 - unit heater S-3S
- 5 - valve with ON/OFF actuator
- 8 - programmable controller HMI BMS
- 9 - relay module RM-16A
- 10 - external temperature sensor

* the electrical circuit should include all safety element required by the law

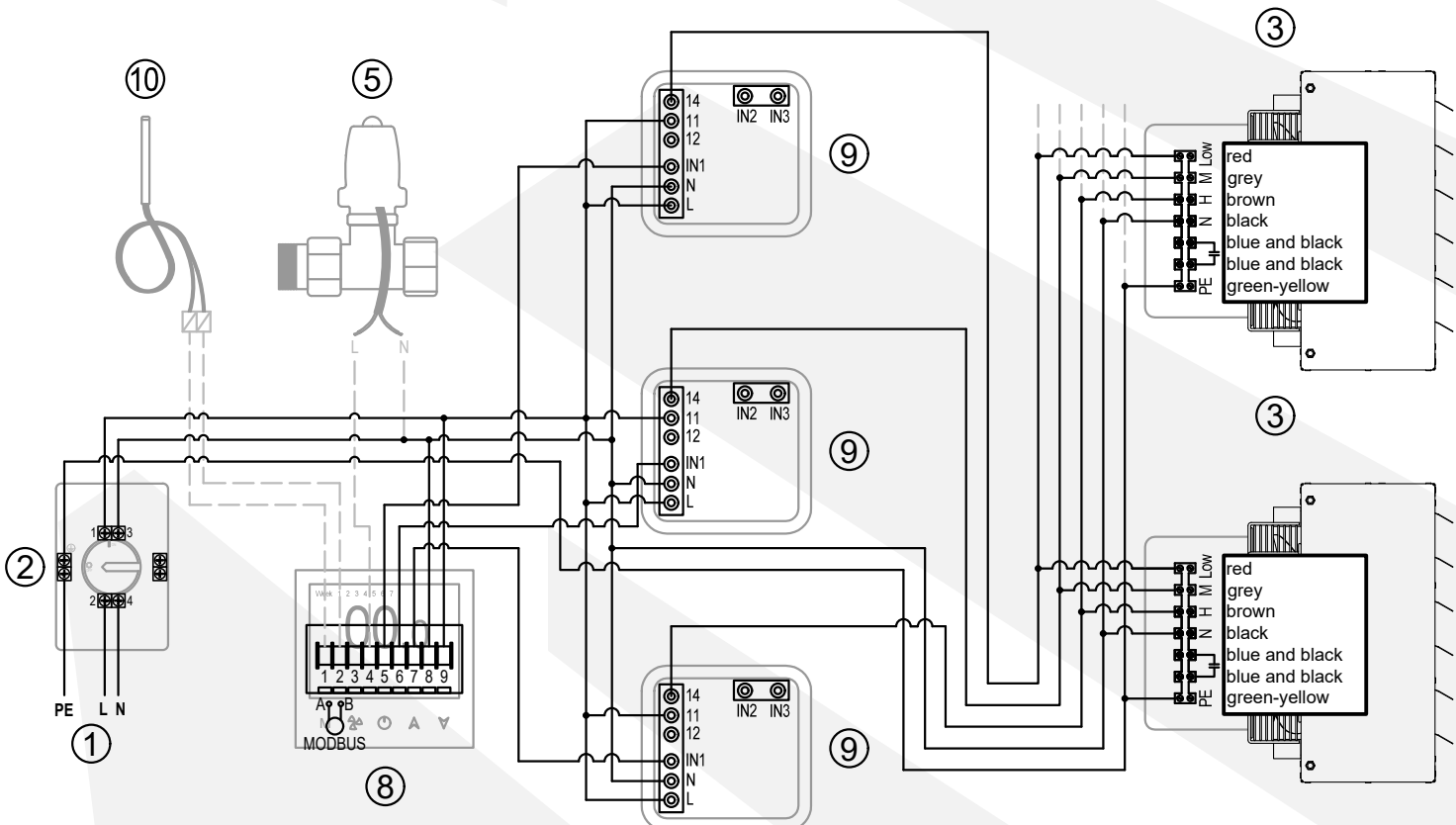

Reventon Group Sp. z o.o.
556 Wyzwolenia Street
43-340 Kozy, Poland

declares under our sole responsibility, that the products:

S1-3S
S2-3S
S3-3S
S4-3S

TYPE: Unit heater

conform to the following directives and regulations:

LVD 2014/35/EU

ErP 2009/125/EC

ROHS 2011/65/EU & (EU) 2015/863

and the following harmonized standards have been applied:

EN 60034-1: 2010

The above declaration is the basis for the  marking.

Place of issue: Poland

Date of Issue: 11/09/2024



Signature: _____

Name: Tomasz Wysocki

Position: Chief Executive Officer



reventon
INDUSTRIAL SOLUTIONS

Reventon Group Sp. z o.o., 556 Wyzwolenia Street, 43-340 Kozy, Poland, www.reventongroup.eu